

Owner's Manual

Electric
Warming Drawer

ZKD910
ZTD910



Monogram.[®]

Introduction

Your new Monogram warming drawer makes an eloquent statement of style, convenience and kitchen planning flexibility. Whether you chose it for its purity of design, assiduous attention to detail—or for both of these reasons—you’ll find that your Monogram warming drawer’s superior blend of form and function will delight you for years to come.

Your Monogram warming drawer was designed to provide the flexibility to blend in with your kitchen cabinetry. Its sleek design can be beautifully integrated into the kitchen.

The information on the following pages will help you operate and maintain your warming drawer properly.

If you have any other questions—in the USA, please call the GE Answer Center® 800.626.2000. In Canada, please call 1.888.880.3030.

Contents

Care and Cleaning

Warming Drawer	11
Rack	11
Stainless Steel	11
Control Knob	11

Consumer Services

Important Phone Numbers	14
Model and Serial Numbers	2
Before You Call For Service	12
Safety Instructions	4, 5
Warranty	15, 16

Warming Drawer

Features of Your Warming Drawer	6
Using the Warming Drawer	6–10
Moisture Selector	7
Rack	8
Proofing	9
Crisping	9

Before using your warming drawer

Read this guide carefully. It is intended to help you operate and maintain your new warming drawer properly.

Keep it handy for answers to your questions.

If you don’t understand something or need more help call in the USA:

GE Answer Center®
800.626.2000,
24 hours a day, 7 days a week.

In Canada, call 1.888.880.3030

Write down the model & serial numbers

You can find them on a label located on the backside of the lower drawer front.

These numbers are also on the Consumer Product Ownership Registration Card packed separately with your warming drawer.

Before sending in this card, please write these numbers here:

Model Number

Serial Number

Use these numbers in any correspondence or service calls concerning your warming drawer.

*If you
received a
damaged
warming
drawer*

Immediately contact the dealer (or builder) that sold you the warming drawer.

*Save time
& money*

Before you request service, check the Before You Call For Service section in the back of this guide.

It lists causes of minor operating problems that you can correct yourself.

*If you
need
service*

To obtain service, see the Consumer Services page in the back of this guide.

We're proud of our service and want you to be pleased. If for some reason you are not happy with the service you receive, here are two steps to follow for further help.

For customers in the USA:

FIRST, contact the people who serviced your appliance. Explain why you are not pleased. In most cases, this will solve the problem.

NEXT, if you are still not pleased, write all the details—including your phone number—to:

Manager, Customer Relations
GE Appliances
Appliance Park
Louisville, KY 40225

For customers in Canada:

FIRST, contact the people who serviced your appliance. Explain why you are not pleased. In most cases, this will solve the problem.

NEXT, if you are still not pleased, write all the details—including your phone number—to:

Manager, Consumer Relations
Camco Inc.
1 Factory Lane, Suite 310
Moncton, N.B. E1C 9M3

IMPORTANT SAFETY INSTRUCTIONS

WARNING!

For your safety, the information in this guide must be followed to minimize the risk of fire or explosion, electric shock, or to prevent property damage, personal injury, or loss of life.

WARNING!—ANTI-TIP BRACE REQUIRED

All warming drawers can tip and injury could result if not properly installed.

To prevent accidental tipping of the warming drawer, attach it to the wall with an anti-tip brace as described in the installation instructions.

SAFETY PRECAUTIONS

When using your appliance, follow basic safety precautions, including the following:

- **Use this appliance only for its intended purpose as described in this guide.**
- **Be sure your appliance is properly installed and grounded** by a qualified technician in accordance with the provided installation instructions.
- **Do not attempt to repair or replace any part of your warming drawer unless it is specifically recommended in this guide.** All other servicing should be referred to a qualified technician.
- **Have the installer show you the location of the circuit breaker or fuse.** Mark it for easy reference.
- **Before performing any service, unplug or disconnect the power supply at the household distribution panel by removing the fuse or switching off the circuit breaker.**
- **Do not leave children alone**—children should not be left alone or unattended in an area where an appliance is in use. They should never be allowed to sit or stand on any part of the appliance.
- **Do not allow anyone to climb, stand or hang on the drawer.** They could damage the warming drawer, or cause severe personal injury.
- **Be sure the warming drawer is securely installed in a cabinet that is firmly attached to the house structure.**
- **Never leave the drawer open when you are not watching the warming drawer.**
- **Always keep combustible wall covering, curtains or drapes a safe distance from your warming drawer.**
- **Always keep wooden and plastic utensils and canned food a safe distance away from your warming drawer.**
- **Teach children not to play with the controls or any other part of the warming drawer.**
- **Do not place more than 50 pounds into the drawer.**
- **The purpose of the warming drawer is to hold hot cooked foods at serving temperature.** Always start with hot food; cold food cannot be heated or cooked in the warming drawer.
- **Do not warm food in the warming drawer for more than two hours.**

SAFETY PRECAUTIONS

- **CAUTION:** Items of interest to children should not be stored in cabinets above the warming drawer; children climbing on the drawer to reach items could be seriously injured.
- Use only dry pot holders—moist or damp pot holders on hot surfaces may result in burns from steam. Do not let pot holders touch hot heating elements. Do not use a towel or other bulky cloth.
- For your safety, never use your appliance for warming or heating the room.
- Do not let cooking grease or other flammable materials accumulate in or near the warming drawer.
- Do not use water on grease fires. Never pick up a flaming pan. Turn the controls off.

Flame in the warming drawer can be smothered by closing the drawer or using a multi-purpose dry chemical or foam-type fire extinguisher.
- Do not touch the heating element or the interior surface of the warming drawer. These surfaces may be hot enough to burn.

REMEMBER: The inside surface of the warming drawer may be hot when the drawer is opened.
- Do not store or use combustible materials, gasoline or other flammable vapors and liquids in the vicinity of this or any other appliance.
- Never leave jars or cans of fat drippings in or near your warming drawer.
- Use care when opening the drawer. Open the drawer a crack and let hot air or steam escape before removing or replacing food. Hot air or steam which escapes can cause burns to hands, face and/or eyes.
- Do not heat unopened food containers. Pressure could build up and the container could burst, causing an injury.
- Keep the vent unobstructed.
- Do not use the warming drawer to dry newspapers. If overheated, they can catch on fire.
- Do not use the warming drawer for a storage area. Items stored in the warming drawer can ignite.
- Do not leave paper products, cooking utensils or food in the warming drawer when not in use.
- Clean only parts listed in the Care and Cleaning section.
- Do not use aluminum foil to line the drawer. Foil is an excellent heat insulator and will trap heat beneath it. This will upset the performance of the drawer and it could damage the interior finish.
- Wear proper apparel. Loose fitting or hanging garments should never be worn while using this appliance.

Read and follow this Safety Information carefully.

SAVE THESE INSTRUCTIONS

Features of Your Warming Drawer

Electric Warming Drawer

Design information

(Not all features are on all models. Appearance may vary.)

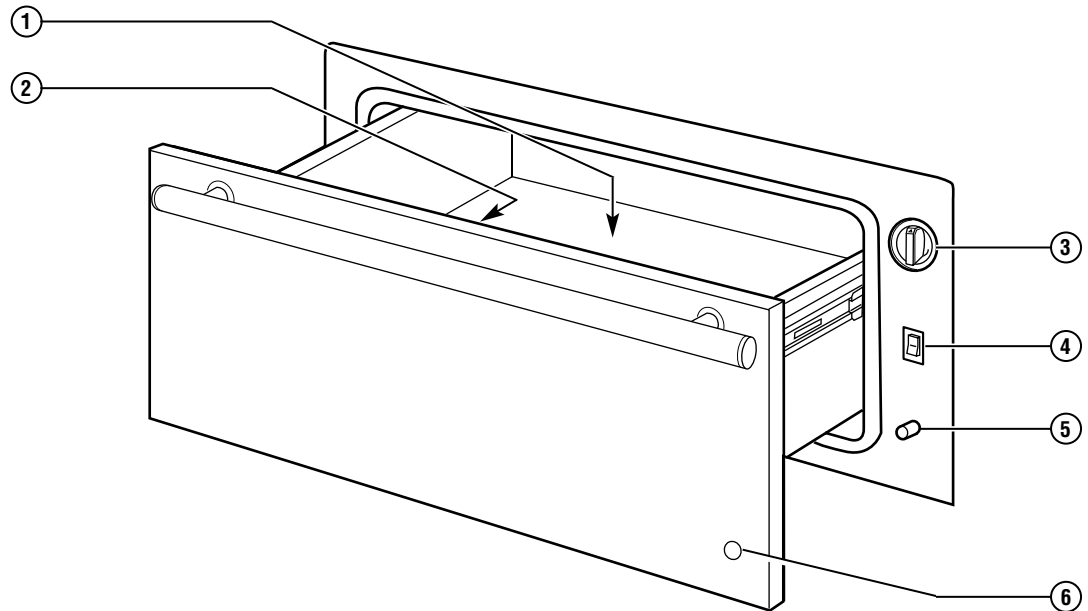

Feature Index	Page
1 Warming Drawer	11
2 Moisture Selector (on back of panel) Use this to keep foods moist or crisp.	7, 9, 10
3 Control Knob The control knob has settings for PROOF, LOW, MED and HIGH .	7
4 ON/OFF Switch Use this switch to turn the warming drawer on.	7
5 ON Signal Light Glowes when the ON/OFF switch is in the ON position.	7
6 ON Signal Light Viewer Lens The ON signal light is visible through the light viewer lens when the drawer is closed.	7

Using the Warming Drawer

Electric Warming Drawer

Control knob

The warming drawer controls are hidden with the drawer shut. Open the drawer. The controls are on the right side of the front frame.

To use the warming drawer, press the **ON/OFF** switch to the **ON** position.

Slide the moisture selector control to the open or closed setting. (See the Moisture Selector section.)

Turn the control knob clockwise to the desired setting.

PROOF . . . 75–95°F.	MED 160–195°F.
LOW 140–160°F.	HIGH 195–230°F.

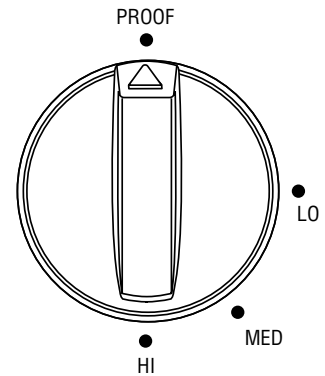

ON signal light

The **ON** signal light is located below the **ON/OFF** switch and glows when the **ON/OFF** switch is in the **ON** position. It stays on until the **ON/OFF** switch is moved to the **OFF** position.

The **ON** signal light is visible through the light viewer in the drawer front panel when the drawer is closed. This is a reminder that the heat is on.

Moisture selector

The moisture selector is located on the inside front of the drawer.

To keep foods moist, slide the moisture selector control away from the control knob. This closes the vent and seals the moisture inside the drawer. With the vent closed hot foods stay moist and soft.

In this setting condensation may occur around the inside edge of the drawer.

To keep foods crisp, slide the moisture selector control to the right towards the control knob. This opens the vents and allows the moisture to escape.

With the vents open, it is normal for moisture to collect on surfaces above the warming drawer.

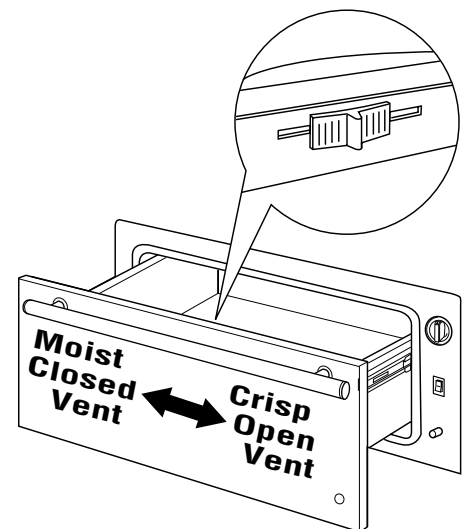

Additional pans

An accessory pan kit **JXPN2** is available from GE at extra cost.

Two pans with lids (4" deep)

- One large pan (14 quarts)
- One medium pan (6 quarts)

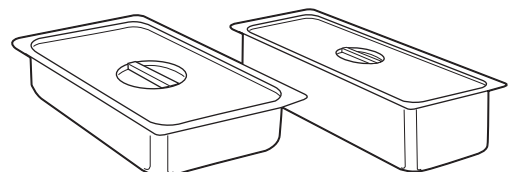

Using the Warming Drawer

Electric Warming Drawer

Rack

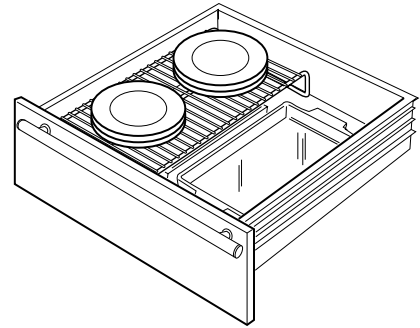
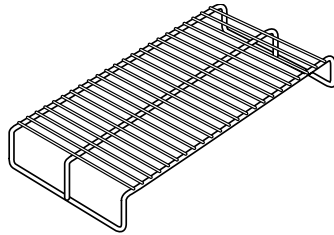

Double stacking items with the rack in position.

- Rack will fit from front to back.
- Preheat with the rack in place.
- Using the rack allows for double stacking of items.

When using the warming drawer...

The warming drawer will keep hot, cooked foods at serving temperature. Always start with hot food. Do not use to heat cold food other than proofing yeast dough, crisping crackers, chips or dry cereal.

Do not line the warming drawer with aluminum foil.

- Allow time for the drawer to be preheated:
LOW 8 minutes
MED 15 minutes
HIGH 20 minutes

NOTE: It is not necessary to preheat the drawer for proofing.

- Food in heat-safe glass and glass ceramic utensils may need higher thermostat setting as compared to food in metal utensils.
- Repeated opening of the drawer allows the hot air to escape and the food to cool. Allow extra time for temperature inside the drawer to stabilize after adding items.

- With large loads it may be necessary to use a higher thermostat setting and cover some of the cooked food items.
- Food should be kept hot in its cooking container or transferred to a heat-safe serving dish.
- Aluminum foil may be used to cover food to prevent it from drying out.

CAUTION: Plastic containers or plastic wrap will melt if in direct contact with the drawer or a hot utensil. Melted plastic may not be removable and is not covered under your warranty.

- Remove serving spoons, etc., before placing containers in warming drawer.

To warm serving bowl and plates

To warm serving bowls and plates set the control on **LOW**.

- Use only heat-safe dishes.
- Place the empty dishes on the rack to raise them off the bottom of the drawer. If you want hotter dishes or want to heat fine china, please check with the manufacturer of the dishes for their maximum heat tolerance.

- Preheat empty serving dish while preheating the drawer.
- When holding hot, cooked foods and warming empty serving dishes at the same time, place the serving dishes on the high rack position and the food on the bottom of the drawer.

CAUTION: Dishes may be hot. Use pot holders or mitts when removing hot dishes.

To proof yeast bread dough

Yeast dough can be proofed in the warming drawer.

- Place your dish on the warming drawer bottom.
- You must always turn the control knob to **LOW** then immediately back to **PROOF**.
- Close the vent.
- Lightly oil the top of the dough in a bowl large enough to double the dough size. Cover with a cloth.
- Preheating not required for proofing.
- Check the dough height in 40 minutes. Add time as needed. The dough should remain in the drawer until it has doubled in size and a slight depression remains when the surface is touched gently with a finger.

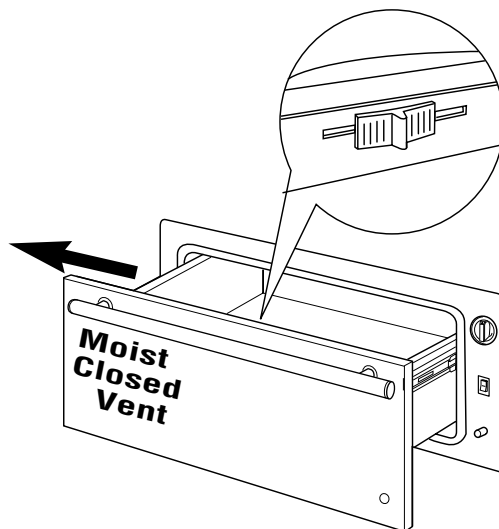

To crisp stale items

- Place food in low sided dishes or pans.
- Preheat on **LOW** setting and open the vent.
- Check crispness after 45 minutes. Add time as needed.

Temperature selection chart for crisp foods

To keep several different foods hot, set the temperature to the food needing the highest setting. Place the items needing the highest setting on the bottom of the drawer and items needing less heat on the rack.

Tips:

- Leave food uncovered.
- Do not use plastic containers or plastic wrap.
- Preheat prior to use according to recommended times.

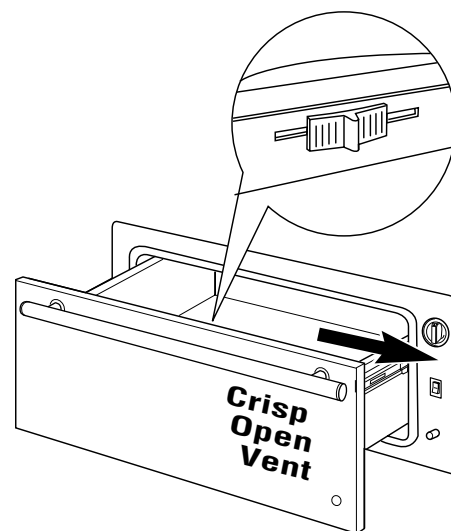

<i>Food Type</i>	<i>Control Setting</i>	<i>Moisture Selector Setting</i>
Bacon	HIGH	OPEN
Bread, hard rolls	MED	OPEN
Fried foods	HIGH	OPEN
Pies, two crusts	MED	OPEN
Pizza	HIGH	OPEN
Potatoes, baked	HIGH	OPEN
Tortilla Chips	LOW	OPEN

Using the Warming Drawer

Electric Warming Drawer

Temperature selection chart for moist foods

To keep several different foods hot, set the temperature to the food needing the highest setting. Place the items needing the highest setting on the bottom of the drawer and items needing less heat on the rack.

Tips:

- Cover food with lid or aluminum foil.
- Do not put water in the warming drawer.
- Do not use plastic containers or plastic wrap.
- Preheat prior to use according to recommended times.

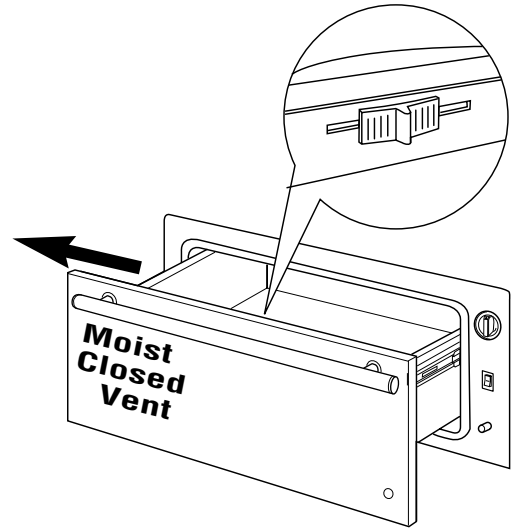

<i>Food Type</i>	<i>Control Setting</i>	<i>Moisture Selector Setting</i>
Beef, medium and well done*	MED	CLOSED
Bread, soft rolls	MED	CLOSED
Casseroles	MED	CLOSED
Cooked cereal	MED	CLOSED
Eggs	MED	CLOSED
Fish, seafood	MED	CLOSED
Fruit	MED	CLOSED
Gravy, cream sauces	MED	CLOSED
Ham	MED	CLOSED
Lamb	MED	CLOSED
Pancakes, waffles	HIGH	CLOSED
Pies, one crust	MED	CLOSED
Pork	MED	CLOSED
Potatoes, mashed	MED	CLOSED
Poultry	HIGH	CLOSED
Vegetables	MED	CLOSED

* USDA/FSIS recommends an internal temperature of 145°F. as the minimum doneness for beef. Use a portable meat thermometer to check internal temperatures.

Care and Cleaning

Electric Warming Drawer

Be sure the controls are in the OFF position and all surfaces are cool before cleaning any part of the warming drawer.

Warming drawer

Use soap and warm water to thoroughly clean.

Rack

Clean the rack with detergent and water. After cleaning, rinse the rack with clean water and dry with a clean cloth.

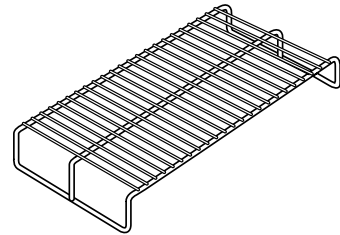

Stainless steel

Do not use a steel wool pad; it will scratch the surface.

To clean the stainless steel surface, use warm sudsy water or a stainless steel cleaner or polish. Always wipe the surface in the direction of the grain. Follow cleaner instructions for cleaning the stainless steel surface.

To inquire about purchasing stainless steel appliances cleaner or polish, or to find the location of a dealer nearest you, please call our toll-free number:

National Parts Center

1.877.959.8688

Control knob

The control knob may be removed for easier cleaning.

Before removing the knob for cleaning, please note that it is in the **PROOF** position.

Wash the knob in soap and water or a vinegar and hot water solution but do not soak.

Dry and replace the knob.

Before You Call For Service...

Electric Warming Drawer

*Save time
and money!*

*Review the
troubleshooting
tips on this
page first and
you may not
need to call
for service.*

PROBLEM	POSSIBLE CAUSE
WARMING DRAWER WILL NOT WORK	<ul style="list-style-type: none">• A fuse in your home may be blown or the circuit breaker tripped. Replace the fuse or reset the circuit breaker.• Warming drawer not plugged in. Plug in.• Warming drawer controls improperly set. See the Using the Warming Drawer section.
DRAWER DOES NOT SLIDE SMOOTHLY OR DRAGS	<ul style="list-style-type: none">• Ball bearings are out of alignment. Fully extend the drawer and push it all the way in. See the Care and Cleaning section.• Drawer over-loaded or load unbalanced. Reduce weight to less than 50 pounds. Redistribute drawer contents.
EXCESSIVE CONDENSATION	<ul style="list-style-type: none">• Liquid in warming drawer. Remove liquid.• Uncovered foods. Cover food with lid or aluminum foil.• Temperature setting too high. Reduce temperature setting.• Incorrect Moisture Selector setting. Set the Moisture Selector to the open vent setting to allow venting.
NO HEAT IN THE PROOF SETTING	<ul style="list-style-type: none">• Room temperature may prevent the thermostat from tripping on. Turn the knob to LOW then back to PROOF.
FOOD DRIES OUT	<ul style="list-style-type: none">• Moisture escaping. Cover food with lid or aluminum foil.

With the purchase of your new Monogram appliance, receive the assurance that if you ever need information or assistance from GE, we'll be there. All you have to do is call—toll-free!

GE Answer Center®

***In the USA:
800.626.2000***

Whatever your question about any Monogram major appliance, GE Answer Center® information service is available to help. Your call—and your question—will be answered promptly and courteously. And you can call any time. GE Answer Center® service is open 24 hours a day, 7 days a week.

In Canada, call 1.888.880.3030.

In-Home Repair Service

***In the USA:
800.444.1845***

***In Canada:
1.888.880.3030***

A GE consumer service professional will provide expert repair service, scheduled at a time that's convenient for you. Many GE Consumer Service company-operated locations offer you service today or tomorrow, or at your convenience (7:00 a.m. to 7:00 p.m. weekdays, 9:00 a.m. to 2:00 p.m. Saturdays). Our factory-trained technicians know your appliance inside and out—so most repairs can be handled in just one visit.

For Customers With Special Needs...

***In the USA:
800.626.2000***

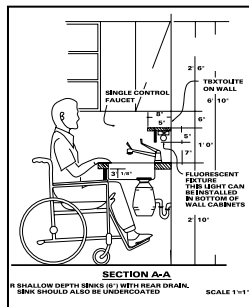

GE offers Braille controls for a variety of GE appliances, and a brochure to assist in planning a barrier-free kitchen for persons with limited mobility.

Consumers with impaired hearing or speech who have access to a TDD or a conventional teletypewriter may call 800.TDD.GEAC (800.833.4322) to request information or service.

Service Contracts

***In the USA:
800.626.2224***

***In Canada:
1.888.880.3030***

You can have the secure feeling that GE Consumer Service will still be there after your warranty expires. Purchase a GE contract while your warranty is still in effect and you'll receive a substantial discount. With a multiple-year contract, you're assured of future service at today's prices.

Parts and Accessories

***In the USA:
800.626.2002***

***In Canada:
1.888.880.3030***

Individuals qualified to service their own appliances can have parts or accessories sent directly to their home. The GE parts system provides access to over 47,000 parts...and all GE Genuine Renewal Parts are fully warranted. VISA, MasterCard and Discover cards are accepted.

User maintenance instructions contained in this guide cover procedures intended to be performed by any user. Other servicing generally should be referred to qualified service personnel. Caution must be exercised, since improper servicing may cause unsafe operation.

YOUR MONOGRAM WARMING DRAWER WARRANTY

Staple sales slip or cancelled check here. Proof of original purchase date is needed to obtain service under warranty.

WHAT IS COVERED

From the Date of the Original Purchase

FULL ONE-YEAR WARRANTY

For one year from date of original purchase, we will provide, free of charge, parts and service labor in your home to repair or replace **any part of the warming drawer** that fails because of a manufacturing defect.

.....
This warranty is extended to the original purchaser and any succeeding owner for products purchased for ordinary home use in the 48 mainland states, Hawaii and Washington, D.C. In Alaska the warranty is the same except that it is LIMITED because you must pay to ship the product to the service shop or for the service technician's travel costs to your home.

All warranty service will be provided by our Factory Service Centers or by our authorized Customer Care® servicers during normal working hours.

Should your appliance need service, during warranty period or beyond, call 800.444.1845.

WHAT IS NOT COVERED

- Service trips to your home to teach you how to use the product.

Read your Use and Care material.

If you then have any questions about operating the product, please contact your dealer or our Customer Relations office at the address below, or call, toll free:

GE Answer Center®
800.626.2000
consumer information service

- Replacement of house fuses or resetting of circuit breakers.
- Failure of the product if it is abused, misused, or used for other than the intended purpose or used commercially.

- Improper installation, delivery or maintenance.

If you have an installation problem, contact your dealer or installer. You are responsible for providing adequate electrical, gas, exhausting and other connecting facilities as described in the Installation Instructions provided with the product.

- Damage to the product caused by accident, fire, floods or acts of God.
- Incidental or consequential damage caused by possible defects with this appliance.
- Damage caused after delivery.

Some states do not allow the exclusion or limitation of incidental or consequential damages, so the above limitation or exclusion may not apply to you. This warranty gives you specific legal rights, and you may also have other rights which vary from state to state.

To know what your legal rights are in your state, consult your local or state consumer affairs office or your state's Attorney General.

Warrantor: General Electric Company. If further help is needed concerning this warranty, write: Manager—Customer Relations, GE Appliances, Louisville, KY 40225

Warranty for customers in Canada

Electric Warming Drawer

YOUR MONOGRAM WARMING DRAWER WARRANTY

Staple sales slip or cancelled check here. Proof of original purchase date is needed to obtain service under warranty.

WHAT IS COVERED

From the Date of the Original Purchase

FULL ONE-YEAR WARRANTY

For one year from date of original purchase, we will provide, free of charge, parts and service labor in your home to repair or replace **any part of the warming drawer** that fails because of a manufacturing defect. This warranty is extended to the original purchaser and any succeeding owner for products purchased for ordinary home use in Canada.

.....
All warranty service will be provided by our Factory Service Centers or by our authorized Customer Care® servicers during normal working hours.

Should your appliance need service, during warranty period or beyond, call 1.888.880.3030.

WHAT IS NOT COVERED

- Service trips to your home to teach you how to use the product.

Read your Use and Care material.

If you then have any questions about operating the product, please contact your dealer or our Consumer Relations office at the address below, or call, toll free: **1.888.880.3030**

- Replacement of house fuses or resetting of circuit breakers.
- Failure of the product if it is abused, misused, or used for other than the intended purpose or used commercially.

- Improper installation, delivery or maintenance.

If you have an installation problem, contact your dealer or installer. You are responsible for providing adequate electrical, gas, exhausting and other connecting facilities as described in the Installation Instructions provided with the product.

- Damage to the product caused by accident, fire, floods or acts of God.
- Incidental or consequential damage caused by possible defects with this appliance.
- Damage caused after delivery.

Some provinces do not allow the exclusion or limitation of incidental or consequential damages, so the above limitation or exclusion may not apply to you. This warranty gives you specific legal rights, and you may also have other rights which vary from province to province. To know what your legal rights are in your province, consult your local or provincial consumer affairs office.

Warrantor: Camco Inc. If further help is needed concerning this warranty, write: Manager, Consumer Relations, Camco Inc., 1 Factory Lane, Suite 310, Moncton, N.B. E1C 9M3.

49-80301

02-05 JR

Printed in the United States



Monogram®

GE Consumer & Industrial
Louisville, KY 40225

©2005 GE Company