

Owner's Manual

36" Chimney
Vent Hood

ZV800



Monogram.[®]

Introduction

Your new Monogram chimney hood makes an eloquent statement of style, convenience and kitchen planning flexibility. Whether you chose it for its purity of design, assiduous attention to detail—or for both of these reasons—you’ll find that your Monogram chimney hood’s superior blend of form and function will delight you for years to come.

Your Monogram chimney hood was designed to provide the flexibility to blend in with your kitchen cabinetry. Its sleek design can be beautifully integrated into the kitchen.

The information on the following pages will help you operate and maintain your chimney hood properly.

Contents

Consumer Information	2, 9–12	Controls and Features	5
Important Phone Numbers	9	Care and Cleaning	
Model and Serial Numbers	2, 12	Charcoal Filter	6
Problem Solver	8	Hood Surfaces	7
Product Registration	2, 11, 12	Light Bulbs	7
Safety Instructions	3, 4	Metal Grease Filters	6
Warranty	10		

Before using your chimney hood

Read this manual carefully. It is intended to help you operate and maintain your new chimney hood properly.

Keep it handy for answers to your questions.

If you don’t understand something or need more help, there is a list of toll-free consumer service numbers included in the back section of this manual.

OR

Visit our Website at: www.monogram.com

Write down the model & serial numbers

You’ll find them on a label on the hood.

These numbers are also on the Consumer Product Ownership Registration Card packed separately with your hood.

Before sending in this card, please write these numbers here:

Model Number

Serial Number

Use these numbers in any correspondence or service calls concerning your hood.

If you received a damaged hood

Immediately contact the dealer (or builder) that sold you the hood.

Save time & money

Before you request service, check the Problem Solver in the back of this manual.

It lists causes of minor operating problems that you can correct yourself.

To obtain service, see the Consumer Services page in the back of this manual.

IMPORTANT SAFETY INSTRUCTIONS

READ ALL INSTRUCTIONS BEFORE USING

SAFETY PRECAUTIONS

WARNING—TO REDUCE THE RISK OF FIRE, ELECTRIC SHOCK OR INJURY TO PERSONS, OBSERVE THE FOLLOWING:

- A. Use this unit only in the manner intended by the manufacturer. If you have questions, contact the manufacturer.
- B. Before servicing or cleaning unit, switch power off at service panel and lock the service disconnecting means to prevent power from being switched on accidentally. When the service disconnecting means cannot be locked, securely fasten a prominent warning device, such as a tag, to the service panel.
- C. Do not use this unit with any solid-state speed control device.
- D. This unit must be grounded.

CAUTION—FOR GENERAL VENTILATING USE ONLY. DO NOT USE TO EXHAUST HAZARDOUS OR EXPLOSIVE MATERIALS AND VAPORS.

WARNING—TO REDUCE THE RISK OF INJURY TO PERSONS IN THE EVENT OF A RANGE TOP GREASE FIRE, OBSERVE THE FOLLOWING*:

- A. SMOTHER FLAMES with a close-fitting lid, cookie sheet or metal tray, then turn off the burner. BE CAREFUL TO PREVENT BURNS. If the flames do not go out immediately, EVACUATE AND CALL THE FIRE DEPARTMENT.
- B. NEVER PICK UP A FLAMING PAN—You may be burned.
- C. DO NOT USE WATER, including wet dishcloths or towels—a violent steam explosion will result.
- D. Use an extinguisher ONLY if:
 - 1. You know you have a Class ABC extinguisher, and you already know how to operate it.
 - 2. The fire is small and contained in the area where it started.
 - 3. The fire department is being called.
 - 4. You can fight the fire with your back to an exit.

*Based on “Kitchen Firesafety Tips” published by NFPA.

WARNING—TO REDUCE THE RISK OF A RANGE TOP GREASE FIRE:

- A. Never leave surface units unattended at high settings. Boilovers cause smoking and greasy spillovers that may ignite. Heat oils slowly on low or medium settings.
- B. Always turn hood ON when cooking at high heat or when flambéing food (ie: Crepes Suzette, Cherries Jubilee, Peppercorn Beef Flambé).
- C. Clean ventilating fans frequently. Grease should not be allowed to accumulate on fan or filter.
- D. Use proper pan size. Always use cookware appropriate for the size of the surface element.

WARNING—TO REDUCE THE RISK OF FIRE, ELECTRIC SHOCK OR INJURY TO PERSONS, OBSERVE THE FOLLOWING:

- A. Installation work and electrical wiring must be done by qualified person(s) in accordance with all applicable codes and standards, including fire-rated construction.
- B. Sufficient air is needed for proper combustion and exhausting of gases through the flue (chimney) of fuel burning equipment to prevent back drafting. Follow the heating equipment manufacturer’s guideline and safety standards such as those published by the National Fire Protection Association (NFPA), and the American Society for Heating, Refrigeration and Air Conditioning Engineers (ASHRAE), and the local code authorities.
- C. When cutting or drilling into wall or ceiling, do not damage electrical wiring and other hidden utilities.
- D. Ducted fans must always be vented to the outdoors.

WARNING—TO REDUCE THE RISK OF FIRE, USE ONLY METAL DUCTWORK.

- Do not attempt to repair or replace any part of your hood unless it is specifically recommended in this manual. All other servicing should be referred to a qualified technician.

READ AND SAVE THESE INSTRUCTIONS.

INSTRUCTIONS DE SÉCURITÉ IMPORTANTES

LISEZ TOUTES LES INSTRUCTIONS AVANT D'UTILISER VOTRE APPAREIL

PRÉCAUTIONS EN MATIÈRE DE SÉCURITÉ

AVERTISSEMENT— **POUR RÉDUIRE LE RISQUE D'INCENDIE, DE** **SECOUSSE ÉLECTRIQUE OU DE BLESSURE** **CORPORELLE, OBSERVEZ LES PRÉCAUTIONS** **SUIVANTES :**

- A. N'utilisez cet appareil que de la manière prévue par le fabricant. Si vous avez des questions, appelez le fabricant.
- B. Avant de réparer ou de nettoyer votre appareil, débranchez le courant au niveau du panneau de service et verrouillez les mécanismes de débranchement de service pour éviter tout branchement accidentel au courant. Si vous ne pouvez pas verrouiller les mécanismes de débranchement de service, attachez soigneusement un avertissement bien visible, comme une étiquette, au panneau de service.
- C. N'utilisez jamais cet appareil avec un mécanisme de réglage de la vitesse à semi-conducteurs.
- D. Cet appareil doit être bien mis à la terre.

ATTENTION—UNIQUEMENT **À USAGE DE VENTILATION GÉNÉRALE.** **N'UTILISEZ JAMAIS POUR L'ÉCHAPPEMENT** **DE MATIÈRES ET DE VAPEURS EXPLOSIVES.**

AVERTISSEMENT— **POUR RÉDUIRE LE RISQUE DE BLESSURE** **CORPORELLE SI DE LA GRAISSE PREND FEU** **SUR LA SURFACE DE CUISSON DU FOUR,** **SUIVEZ LES INSTRUCTIONS SUIVANTES* :**

- A. ÉTOUFFEZ LES FLAMMES avec un couvercle qui convient, une tôle à biscuits ou un plateau en métal, puis éteignez le brûleur. FAITES BIEN ATTENTION DE NE PAS VOUS BRÛLER. Si les flammes ne s'éteignent pas immédiatement, SORTEZ ET APPELÉZ LES POMPIERS.
- B. NE DÉPLACEZ JAMAIS UNE CASSEROLLE QUI FLAMBE—Vous pouvez vous brûler.
- C. N'UTILISEZ JAMAIS D'EAU, en particulier de serviette ou de chiffon mouillé—il se produira une explosion violente de vapeur brûlante.
- D. N'UTILISEZ UN EXTINCTEUR que si :
 1. Vous avez un extincteur de classe ABC et vous savez comment l'utiliser;
 2. Le feu est réduit et confiné à l'endroit où il a commencé;
 3. Vous avez déjà appelé les pompiers;
 4. Vous combattez les flammes en tournant le dos à une sortie.

* Basé sur l'ouvrage intitulé «Kitchen Fire Safety Tips» publié par la NFPA.

AVERTISSEMENT—POUR **RÉDUIRE LE RISQUE D'UN FEU DE GRAISSE** **SUR LA SURFACE DE CUISSON DU FOUR :**

- A. Ne laissez jamais sans surveillance les unités de cuisson de surface à une température élevée. Le bouillonnement occasionne des débordements fumants et grasseux qui peuvent prendre feu. Chauffez à feu doux les substances huileuses, avec un réglage bas ou moyen.
- B. Mettez toujours la hotte en marche quand vous cuisinez à haute température ou quand vous faites flamber des aliments (p. ex. crêpes Suzette, cerises Jubilee, Bœuf flambé Peppercorn).
- C. Nettoyez les mécanismes de ventilation fréquemment. Il ne faut pas permettre une accumulation de graisse sur le ventilateur ou sur le filtre.
- D. Utilisez une casserole de bonne taille. Utilisez toujours un ustensile de cuisine qui convienne au diamètre de l'élément de cuisson.

AVERTISSEMENT— **POUR RÉDUIRE LE RISQUE D'INCENDIE, DE** **SECOUSSE ÉLECTRIQUE OU DE BLESSURE** **CORPORELLE, OBSERVEZ LES PRÉCAUTIONS** **SUIVANTES :**

- A. Vous devez faire exécuter tous les travaux d'installation et de câblage électrique par une personne qualifiée, conformément à tous les codes et les normes en vigueur, y compris une construction cotée pour l'incendie.
- B. Vous devez assez d'air pour avoir une bonne combustion et permettre l'évacuation des gaz par le conduit de cheminée du matériel de combustion du carburant, afin d'éviter tout retour d'air. Suivez les directives du fabricant de matériel de combustion et les normes de sécurité comme celles publiées par la National Fire Protection Association (NFPA) et l'American Society for Heating, Refrigeration and Air Conditioning Engineers (ASHRAE), ainsi que les modalités des codes locaux.
- C. Si vous faites un trou ou une ouverture dans un mur ou un plafond, n'endommagez pas les fils électriques et les autres installations cachées de service public.
- D. Vous devez toujours alimenter les ventilateurs dans les conduits en air en provenance de l'extérieur.

AVERTISSEMENT—POUR **RÉDUIRE LE RISQUE D'INCENDIE, N'UTILISEZ** **QUE DES CONDUITS EN MÉTAL.**

- N'essayez jamais de remplacer ou de réparer un élément de votre hotte si le présent manuel ne le recommande pas expressément. Tout autre entretien doit être effectué par un technicien qualifié.

LISEZ ET CONSERVEZ CES INSTRUCTIONS.

Glass visor

Grasp the visor and pull it out to more efficiently remove steam when cooking. Push it back when not in use.

NOTE: The vent fan will work with the visor in or out.

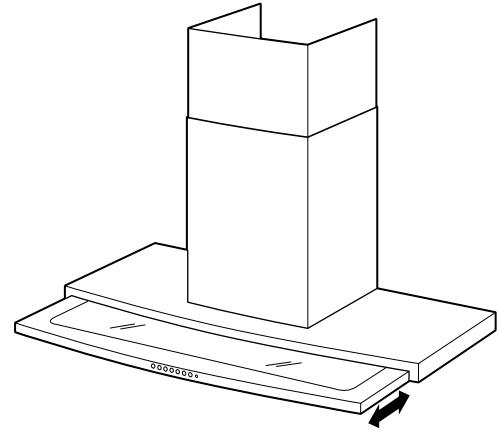

Controls

NOTE: Avoid using food products that produce flames under the range hood.

- 1 Light ON/OFF. It remembers the last light level used. (Six light levels.)
- 2 Dims the light.
- 3 Brightens the light.
- 4 ON/OFF. It remembers the last fan speed used. (Four speed fan.)
- 5 Decreases the speed.
- 6 Increases the speed.
- 7 BOOST—The highest fan speed.

NOTE: The BOOST fan speed can only be selected with this control. BOOST is not accessible by cycling up to the highest fan speed using the increase fan button.

- 8 Fan indicator. The light will turn on when the fan is operating.

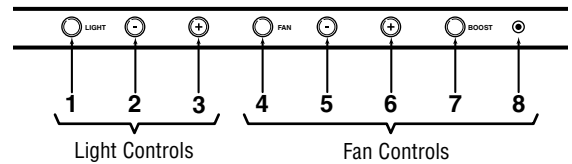

For your safety

Before servicing or cleaning unit, switch power off at service panel and lock the service disconnecting means to prevent power from being switched on accidentally.

When the service disconnecting means cannot be locked, securely fasten a prominent warning device, such as a tag, to the service panel.

Metal grease filters

The metal filters trap grease released by foods on the cooktop. The filters also help prevent flames (from food, grease) from damaging the inside of the hood.

For this reason, the filters must ALWAYS be in place when the hood is used. The grease filters should be cleaned every 6 months, or as needed.

To clean the grease filters, soak them and then swish them around in hot water and detergent. Don't use ammonia or ammonia products because they will darken the metal. Do not use abrasives or oven cleaners. Light brushing can be used to remove embedded dirt. Rinse, shake and let them dry before replacing.

The metal grease filters may also be cleaned in an automatic dishwasher.

To remove:

Pull the visor out. Grasp the filter lock and pivot it open to release. Pull the filter down and out. Remove both filters.

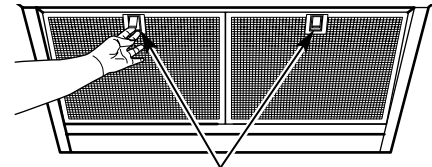

Filter Locks

To replace:

1. Insert the two tabs on the bottom filter edge into the slots in the back of the hood.
2. Push the front of the filter up, open the filter lock and snap it into place in the hood.

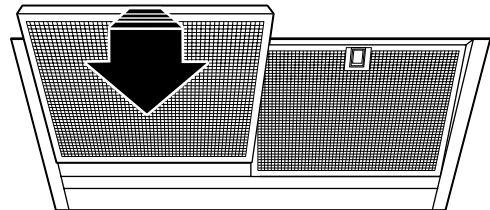

Charcoal filter

(on some models)

If the model is not vented to the outside, the air will be recirculated through a disposable charcoal filter that helps remove smoke and odors.

The charcoal filter should be replaced when it is noticeably dirty or discolored (usually after 6 to 12 months, depending on hood usage).

NOTE: DO NOT rinse, or put charcoal filter in an automatic dishwasher.

The charcoal filter cannot be cleaned. It must be replaced.

Order Charcoal Filter Kit (3 filters) WB02X10731.

This kit can be ordered from your GE Supplier.

To remove:

1. Pull the visor out.
2. Remove the two metal filters—see *Metal grease filters* section above.
3. Grasp the front of the charcoal filter and pull it down and out.

To replace:

Insert the back of the charcoal filter edge into the opening in the rear (center), push the front of the filter up and snap it into place in the hood. Replace the two metal filters.

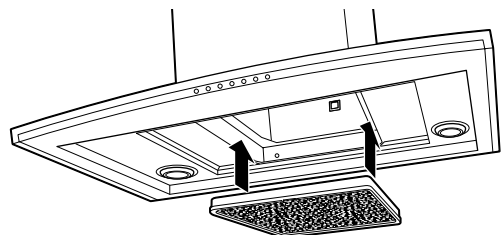

Stainless steel surfaces

(on some models)

Do not use a steel wool pad; it will scratch the surface.

To clean the stainless steel surface, use warm sudsy water, a stainless steel cleaner such as Kleen King® or an all-purpose liquid or spray cleaner. Always scrub in the direction of the grain. Rinse thoroughly with a sponge or cloth and clean water. Dry with a soft, clean cloth.

After cleaning, use a stainless steel polish, such as Stainless Steel Magic®, Revere Copper and Stainless Steel Cleaner® or Weno! All Purpose Metal Polish®. Follow the product instructions for cleaning the stainless steel surface.

Painted Surfaces

(on some models)

Clean any painted surfaces with a mixture of water and either soap or vinegar.

Do not use commercial oven cleaners, cleaning powders, steel wool or harsh abrasives on any painted surface.

Glass visor

Pull the glass visor out and wash it with a damp soapy cloth. Dry it with a clean cloth and push it back into place.

Light bulbs

NOTE: The glass cover should be removed only when cold. Wearing latex gloves may offer a better grip.

CAUTION: Before replacing the bulb, disconnect electrical power to the hood at the main fuse or circuit breaker panel.

ATTENTION : Avant de remettre en place l'ampoule, débranchez le courant de la hotte en enlevant le fusible principal ou en faisant basculer le disjoncteur au panneau d'alimentation.

Be sure to let the light cover and bulb cool completely.

For your safety, do not touch a hot bulb with bare hands or a damp cloth.

To remove:

- 1 Insert your finger nail into the inner glass cover slot and pull down. Remove cover.

NOTE: Do not remove outer retaining ring.

- 2 Using gloves or a dry cloth, remove the bulb by pulling it straight out.

To replace:

- 1 Use a new 12-volt, 20-watt Halogen bulb for a G-4 base.
- 2 Using gloves or a dry cloth, remove the new bulb from its packaging.

NOTE: Do not touch the new halogen bulb with bare fingers. Touching the bulb with bare fingers will significantly reduce the life of the bulb.

- 3 Push the bulb straight into the receptacle all the way.

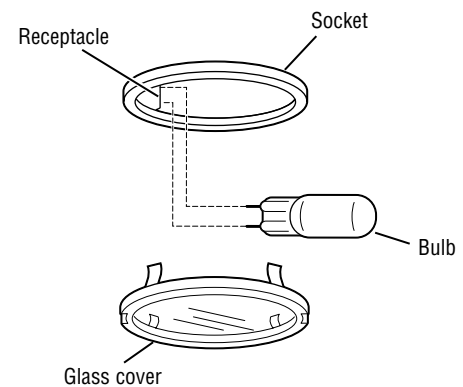

ONLY use a new 12-volt, 20-watt Halogen bulb for a G-4 base.

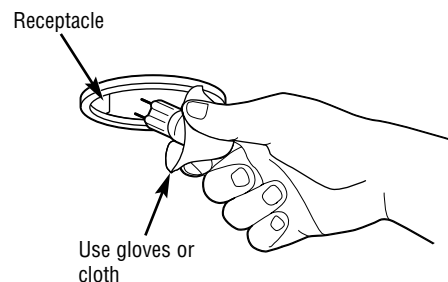

For improved lighting, clean the glass cover frequently using a damp cloth. This should be done when the hood is completely cool.

- 4 Snap the glass cover into the retaining ring.
- 5 Reconnect electrical power to the hood.

The Problem Solver

Chimney Vent Hood

Questions?

*Use this
problem
solver!*

PROBLEM	POSSIBLE CAUSE
FAN DOES NOT OPERATE WHEN THE SWITCH IS ON	<ul style="list-style-type: none">• A fuse may be blown or a circuit breaker tripped. Replace fuse or reset circuit breaker.
FAN FAILS TO CIRCULATE AIR	<ul style="list-style-type: none">• Fan blade striking the hood shell.• Excessively soiled filter should be checked and corrected before using the hood again.
FAN OPERATES BUT MOVES AIR SLOWER THAN NORMAL	<ul style="list-style-type: none">• Check to be sure the filter is clean. If replacing the filter does not correct the problem, call for service.
FAN KEEPS GOING OFF AND ON	<ul style="list-style-type: none">• The motor is probably overheating and turning itself off. This can be harmful to the motor. Check to be sure the filter is clean. If it continues to cycle on and off, call for service.
FAN LIGHT IS ON OR IS BLINKING	<ul style="list-style-type: none">• This is normal and indicates the fan is operating as it should.

With the purchase of your new Monogram appliance, receive the assurance that if you ever need information or assistance from GE, we'll be there. All you have to do is call—toll-free!

GE Answer Center®

800.626.2000

If you have any questions about GE Monogram appliances, the GE Answer Center® is available anytime—24 hours a day, 7 days a week. Your call will be answered promptly and courteously.

OR

Visit our Website at: www.monogram.com

In-Home Repair Service

800.444.1845

A GE consumer service professional will provide expert repair service, scheduled at a time that's convenient for you. Many GE Consumer Service company-operated locations offer you service today or tomorrow, or at your convenience (7:00 a.m. to 7:00 p.m. weekdays, 9:00 a.m. to 2:00 p.m. Saturdays). Our factory-trained technicians know your appliance inside and out—so most repairs can be handled in just one visit.

For Customers With Special Needs...

800.626.2000

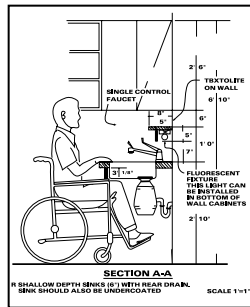

GE offers, free of charge, a brochure to assist in planning a barrier-free kitchen for persons with limited mobility.

Consumers with impaired hearing or speech who have access to a TDD or a conventional teletypewriter may call 800.TDD.GEAC (800.833.4322) to request information or service.

Service Contracts

800.626.2224

You can have the secure feeling that GE Consumer Service will still be there after your warranty expires. Purchase a GE contract while your warranty is still in effect and you'll receive a substantial discount. With a multiple-year contract, you're assured of future service at today's prices.

Parts and Accessories

800.626.2002

Individuals qualified to service their own appliances can have parts or accessories sent directly to their home. The GE parts system provides access to over 47,000 parts...and all GE Genuine Renewal Parts are fully warranted. VISA, MasterCard and Discover cards are accepted.

User maintenance instructions contained in this manual cover procedures intended to be performed by any user. Other servicing generally should be referred to qualified service personnel. Caution must be exercised, since improper servicing may cause unsafe operation.

YOUR MONOGRAM HOOD WARRANTY

Staple sales slip or cancelled check here. Proof of original purchase date is needed to obtain service under warranty.

WHAT IS COVERED

FULL ONE-YEAR WARRANTY

For one year from date of original purchase, we will provide, free of charge, parts and service labor in your home to repair or replace **any part of the hood** that fails because of a manufacturing defect.

.....

This warranty is extended to the original purchaser and any succeeding owner for products purchased for ordinary home use in the 48 mainland states, Hawaii and Washington, D.C. In Alaska the warranty is the same except that it is LIMITED because you must pay to ship the product to the service shop or for the service technician's travel costs to your home.

All warranty service will be provided by our Factory Service Centers or by our authorized Customer Care® servicers during normal working hours.

Should your appliance need service, during warranty period or beyond, call 800.444.1845.

WHAT IS NOT COVERED

- | | |
|---|---|
| <ul style="list-style-type: none">• Service trips to your home to teach you how to use the product.• Replacement of house fuses or resetting of circuit breakers.• Incidental or consequential damage caused by possible defects with this appliance.• Replacement of the replaceable filters.• Damage to the product caused by accident, fire, floods or acts of God.• Failure of the product if it is used for other than its intended purpose or used commercially. | <ul style="list-style-type: none">• Improper installation, delivery or maintenance. <p>If you have an installation problem, contact your dealer or installer. You are responsible for providing adequate electrical, gas, exhausting and other connecting facilities as described in the Installation Instructions provided with the product.</p> <ul style="list-style-type: none">• Damage caused after delivery. |
|---|---|

Some states do not allow the exclusion or limitation of incidental or consequential damages, so the above limitation or exclusion may not apply to you. This warranty gives you specific legal rights, and you may also have other rights which vary from state to state.

To know what your legal rights are in your state, consult your local or state consumer affairs office or your state's Attorney General.

Warrantor: General Electric Company, Louisville, KY 40225

**Consumer Product
Ownership Registration**
Important Mail Today

GE Appliances



Place
1st Class
Letter
Stamp
Here

General Electric Company
Warranty Registration Department
P.O. Box 32150
Louisville, KY 40232-2150

Consumer Product Ownership Registration

Dear Customer:

Thank you for purchasing our product and thank you for placing your confidence in us. We are proud to have you as a customer!

Follow these three steps to protect your new appliance investment:



1 Complete and mail your Consumer Product Ownership Registration today. Have the peace of mind of knowing we can contact you in the unlikely event of a safety modification.

2 After completing this registration, write your model and serial numbers in this manual. You will need this information should you require service. The service number in the USA: 800.444.1845. In Canada: 1.888.880.3030.

3 Read your Owner's Manual carefully. It will help you operate your new appliance properly.

Important: To ensure that your product is registered, mail the separate product registration card. If the separate product registration card is missing, fold and mail the form below. No envelope is needed.

FOLD HERE

Consumer Product Ownership Registration



Product

Hood

Model

Serial

Mr. Ms. Mrs. Miss

First Name _____ Last Name _____

Street Address _____

Apt. # _____

City _____ State _____ Zip Code _____

Date Placed In Use Month _____ Day _____ Year _____ Phone Number _____-_____-_____

Occasionally, we may allow selected companies to send you information.

Check here if you do not want this information.

FAILURE TO COMPLETE AND RETURN THIS CARD DOES NOT DIMINISH YOUR WARRANTY RIGHTS.

For information about GEA's privacy and data usage policy, go to www.GEAppliances.com and click on "Privacy Policy" or call 800.626.2224.



TAPE CLOSED

49-80268

04307342 07-04 JR

Printed in Italy



Monogram.

GE Consumer & Industrial
Louisville, KY 40225

©2004 General Electric Company